

Installation guide for solar panels for eternit roofing From FIXNORDIC

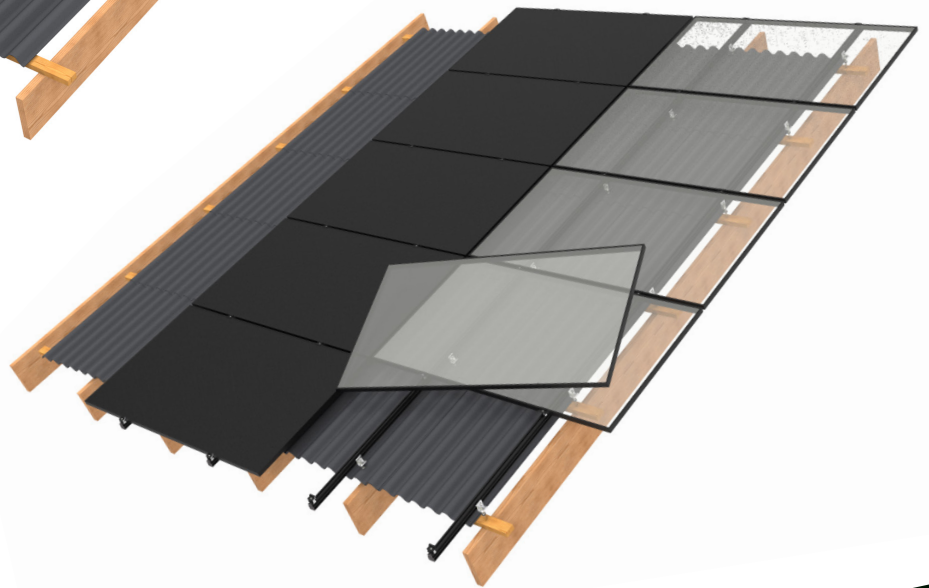

FIXNORDIC.DK

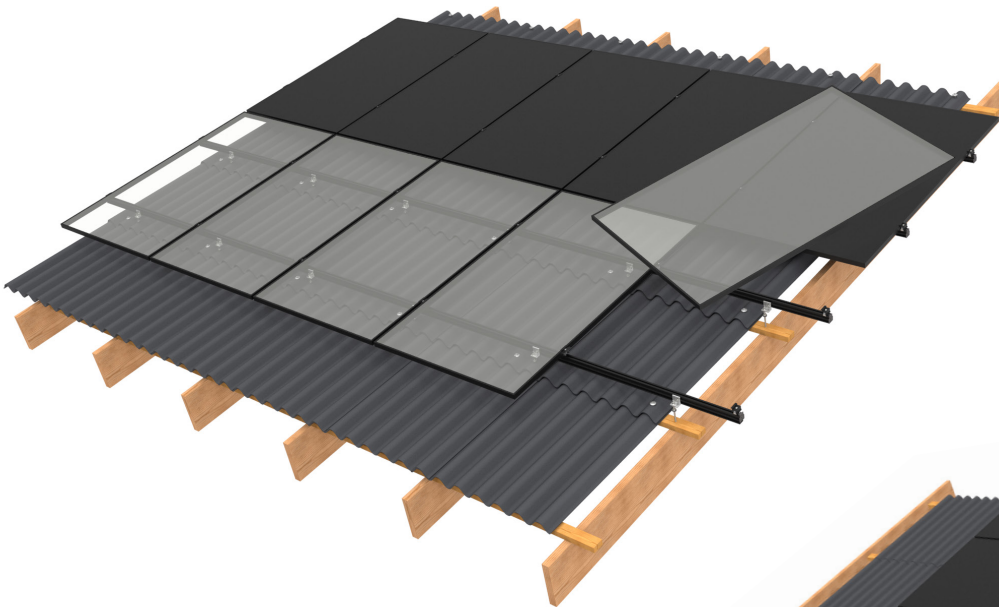

INSTALLATION GUIDE

Assembly system for eternit
From FIXNORDIC

1 ASSEMBLY SYSTEM FOR ETERNIT – GENERAL INFORMATION

The FIXNORDIC assembly system is mounted on building trusses with screws for eternit roofs. The system is simple and easy to work with and can be quickly assembled. The system consists primarily of aluminum alloy and stainless steel, which means that the system corresponds to the lifetime of an ordinary roof.

Wind and snow

Having a roof-parallel system means placing a "new" roof on top of the existing roof. The entire weight from the system and eventual snow load goes directly and efficiently via hanger bolts into the load-bearing roof structure.

The FIXNORDIC assembly system for eternit is mounted in each truss to comply with the normal requirements for wind and snow loads found in Denmark.

The solution is specified to achieve the greatest possible flexibility for the general assembly situation.

The mounting system for eternity roof includes:

- Hanger bolts for eternit
- Carriage profiles in glossy or black anodized aluminium, as well as connectors to connect the profiles
- Black end plugs
- In addition, panel clamps for the appropriate panel thickness in black anodized aluminum

The components are specified on the following 2 pages.



2 ARTICLE NUMBER OVERVIEW (carriage profiles parallel to the roof ridge)

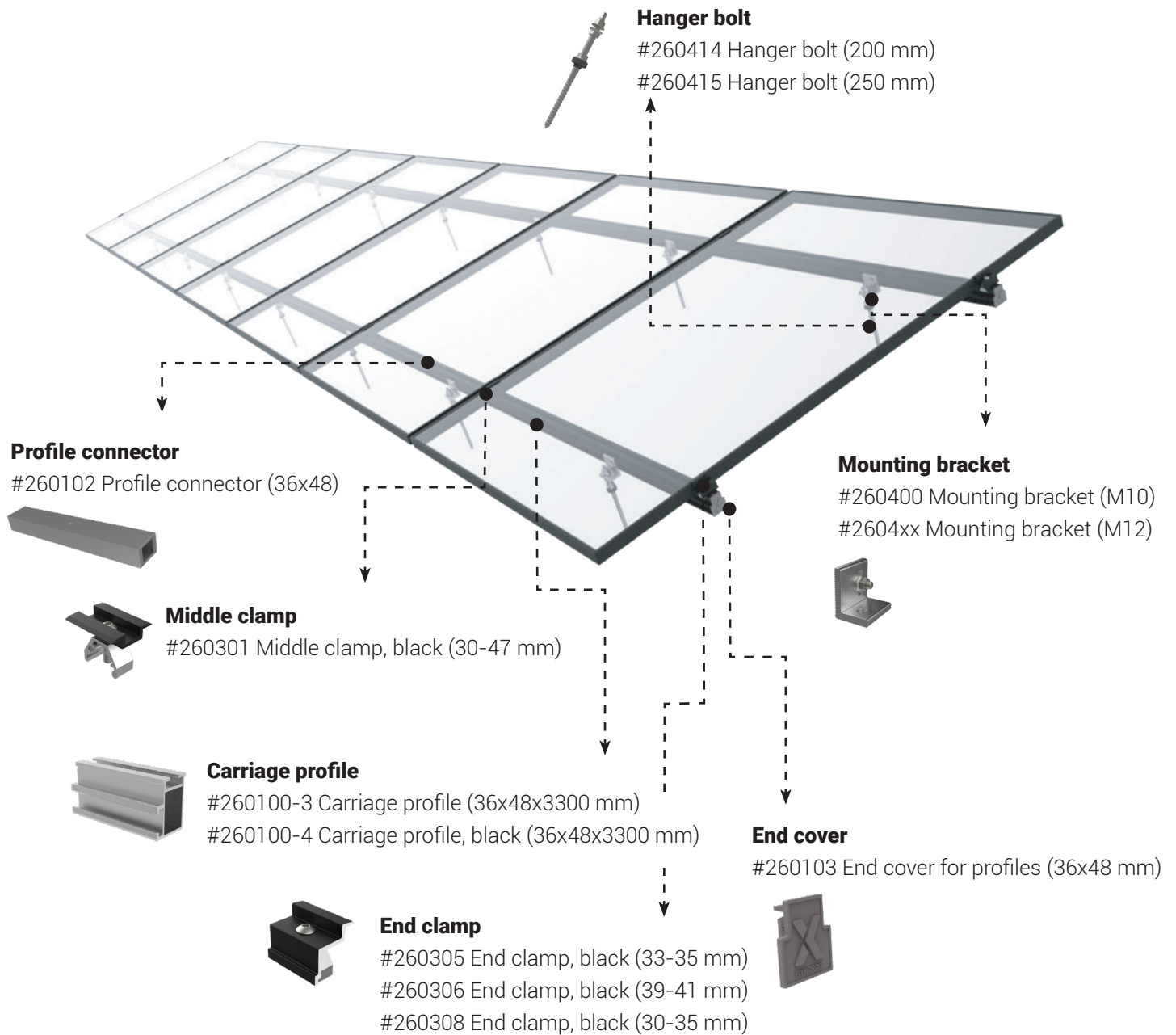

3 ARTICLE NUMBER OVERVIEW (carriage profiles perpendicular to the roof ridge)

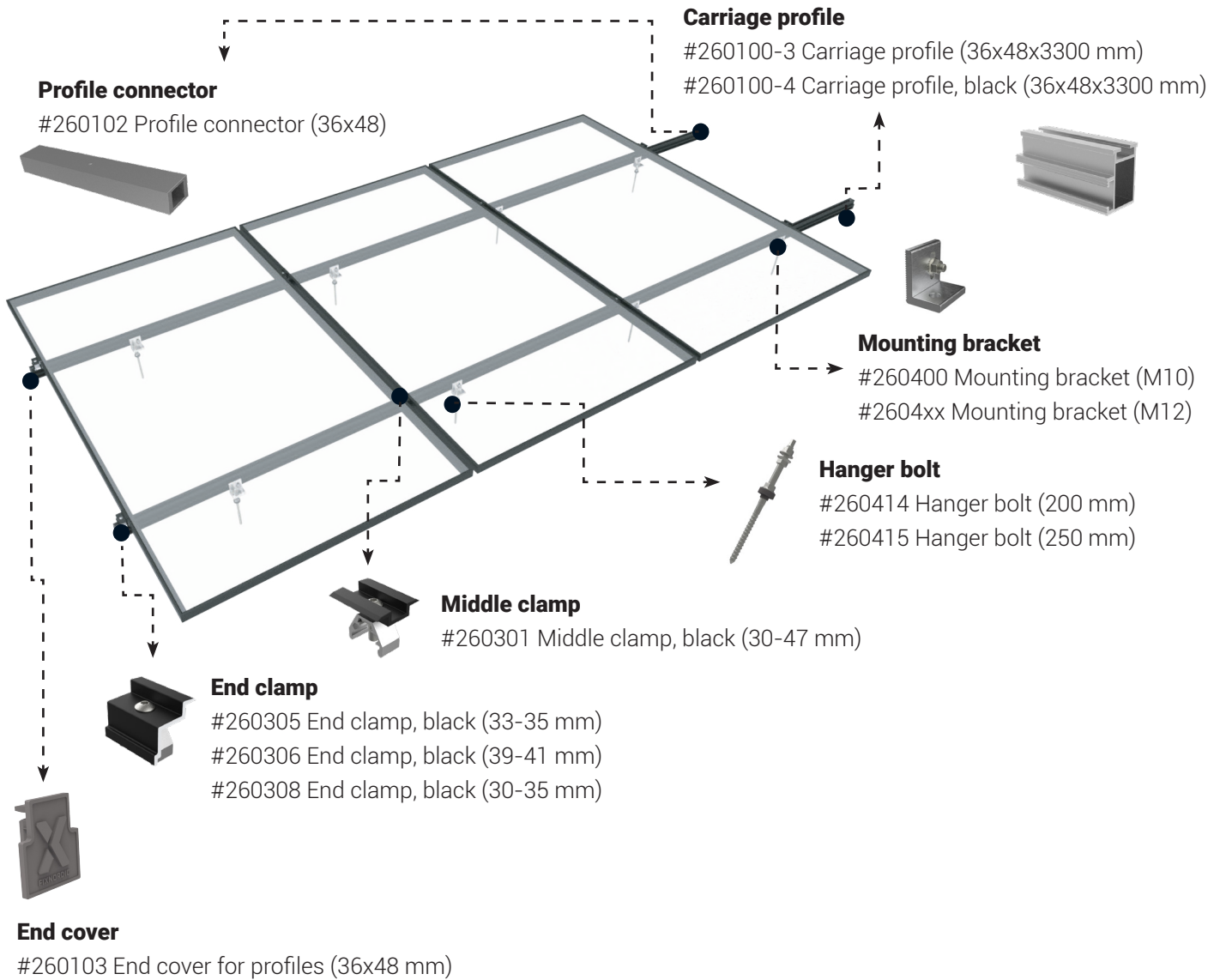

1. Location of hanger bolts

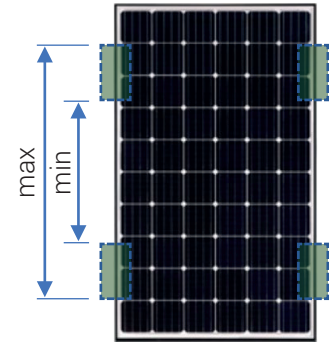
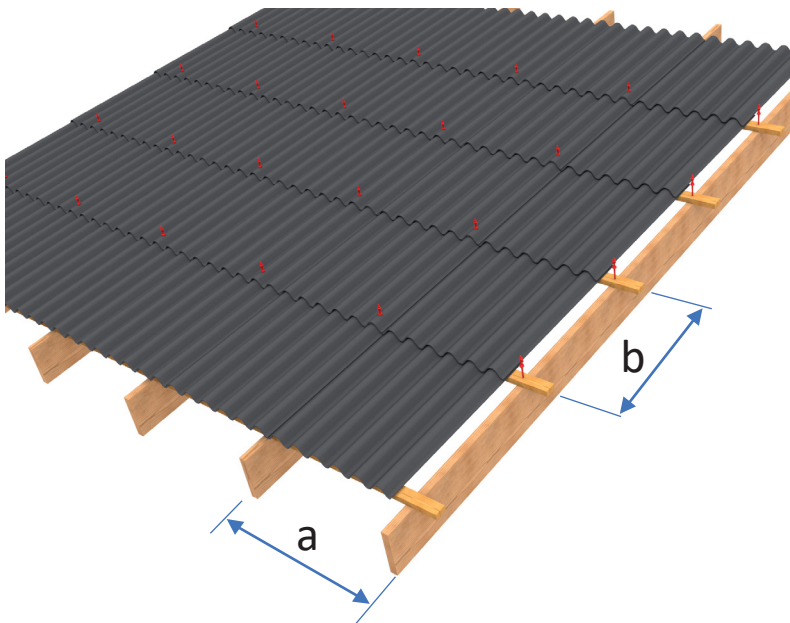

! Acceptable panel clamping zones of panel datasheet.

Eternit screws: By measuring, the trusses and thus the truss distance (a) as well as the position of the horizontal battens and their distance from each other (b) are located within the area where the solar panels are intended to be mounted, and on this basis the position of the hanger bolts is defined, as they are mounted at all intersections between trusses and battens. It is important that the hanger bolts end with a position that ensures that the carriage profiles can form the basis for a panel attachment, cf. the specified clamping zones for the current solar panel.

2. Installation of hanger bolts

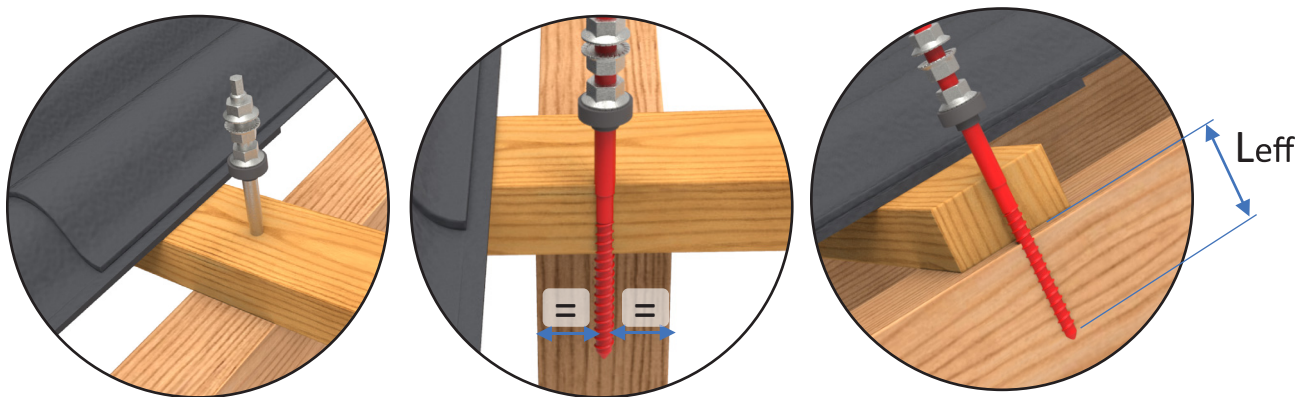

NOTE! Installation of the hanger bolts is only to take place in the middle of the trusses, and not in the battens alone, as these are often not dimensioned for this type of load.

When the hanger bolt is installed, the effective thread length (L_{eff}) in the load-bearing wooden trusses shall be at least 50 mm.



5 INSTALLATION ON ETERNIT ROOFING

Please also note that the hanger bolts are only to be mounted in the corrugated tops to ensure the waterproofness of the roof surface.

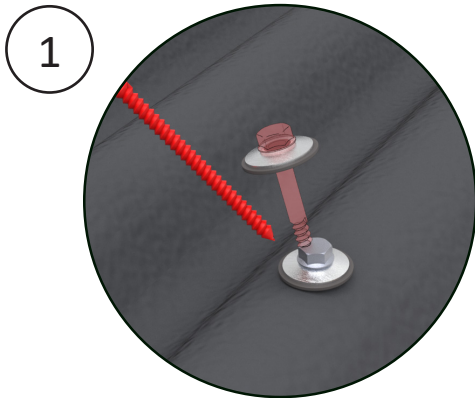

In the case where there is an eternit screw at the point where the hanger bolt is to be installed, the eternit screw shall be removed. If it is necessary to remove all screws around a specific eternit sheet, care must be taken to ensure that the sheet does not slip down the roof surface.

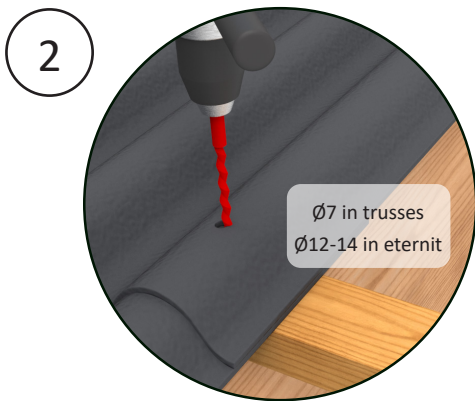

The hole in the truss is drilled up with a Ø7 mm drill and, subsequently, the hole in the eternit sheet is drilled up to 12 – 14 mm.

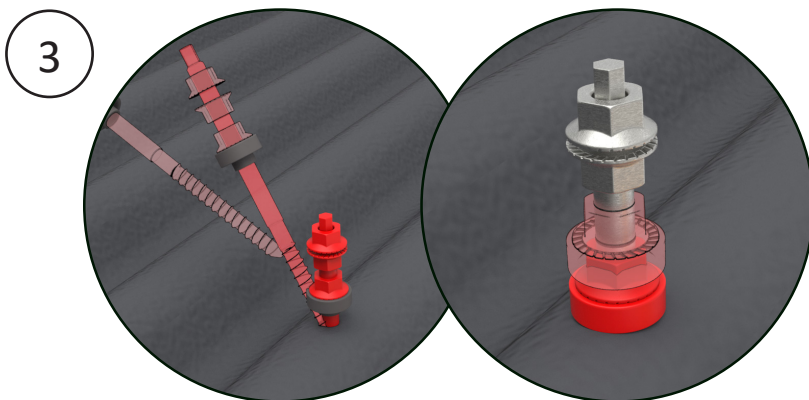

The hanger bolt is mounted and it is ensured that the rubber membrane of the hanger bolt is sufficiently tightened against the corrugated plate to ensure the waterproofness of the roof surface, but be careful not to overtighten.



3. Installation of carriage profiles

Portrait (vertically) oriented panels

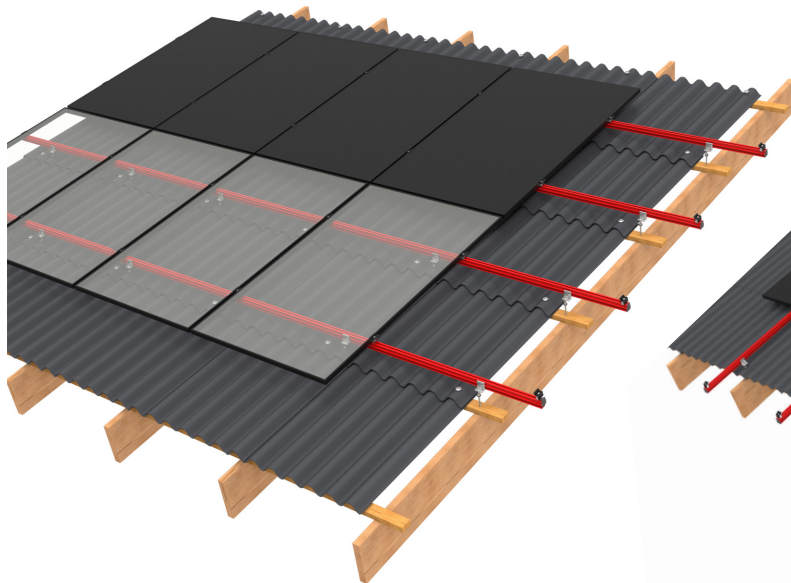

Landscape (horizontally) oriented panels

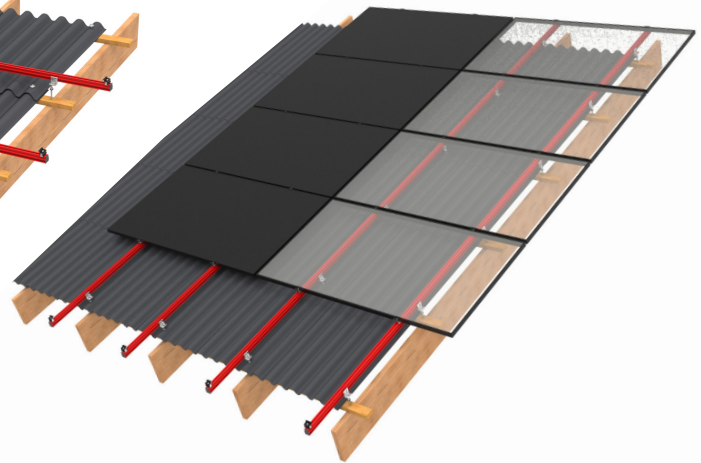

1

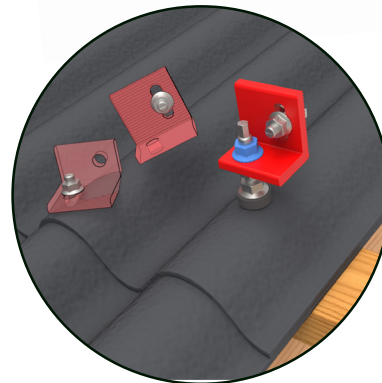
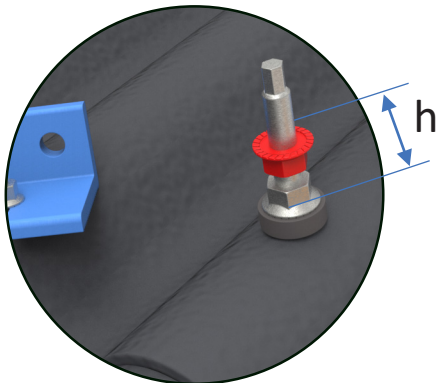

First, the mounting height of the mounting bracket above the eternit sheet is determined and the support nut is set. With the nut at the correct height, the mounting bracket is mounted onto the hanger bolt and the upper nut is screwed on.

2

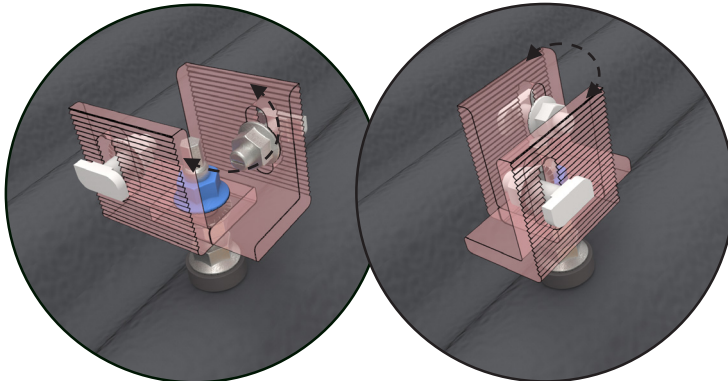

The mounting bracket is oriented according to the intended profile direction; perpendicular or parallel to the roof ridge for portrait or landscape panels, respectively. For landscape panels, a more detailed explanation follows.



3a. Installation of carriage profiles (portrait panels)

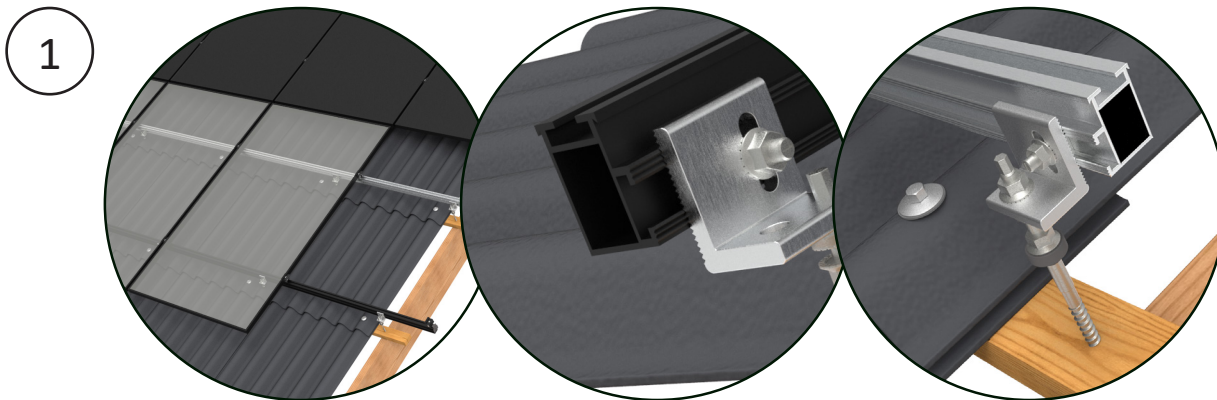

The first profile, which is oriented down towards the eaves, may be visible. In cases where a visually uniform finish is desired, the first profile can be chosen mounted on the underside of the hanger bolt, so that the upper part of the hanger bolt is not visible. Different anodized profiles can also be selected, so that the profiles can have the same colour as the panels.

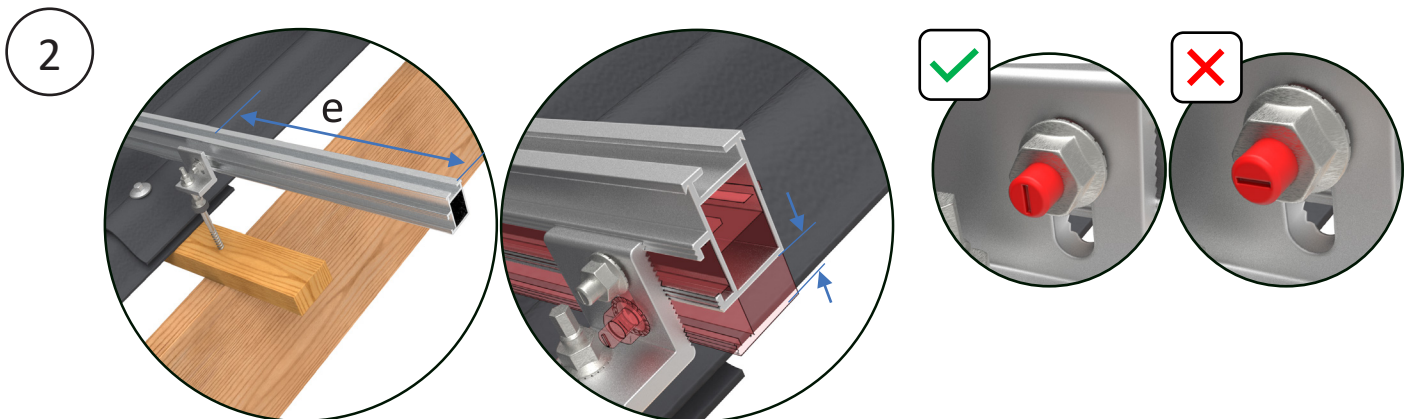

During the installation of the carriage profiles, care shall be taken to ensure that the maximum end overhang (e) does not exceed 400 mm. In relation to the roof perpendicular adjustment of the carriage profiles to the intended mounting plane, this is done efficiently via the extruded grooves in both the carriage profile and mounting brackets. Then the mounting bracket shall be adjusted in relation to the intended mounting plane and the flange nut is tightened (30 Nm).

When the desired height is reached, tighten the nut on the hanger bolt so that the hammerhead bolt is rotated 90° at the same time as the nut is tightened (15 Nm). When the tightening is done, check that the hammerhead bolt is engaged with the profile and oriented correctly, and that the assembly seems solid.



3b. Installation of carriage profiles (landscape panels)

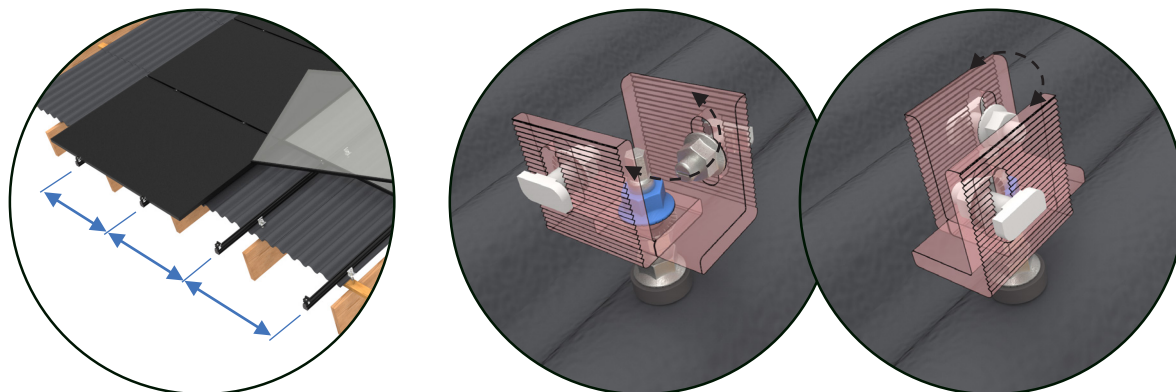

Before the mounting bracket is finally tightened, it must be determined which side of the hanger bolt the carriage profile is to be mounted on. This is done taking into account an overall drawing of where the carriage profiles will be placed on each row of solar panels in relation to the acceptable clamping zones, cf. the panel datasheet (see section 1).

The mounting bracket is mounted on the hanger bolt with the pre-mounted flange nut, which is first removed from the bracket, after which the bracket is mounted and loosely tightened. Then the mounting bracket is adjusted in relation to the intended mounting plane, and the flange nut is tightened (30 Nm).

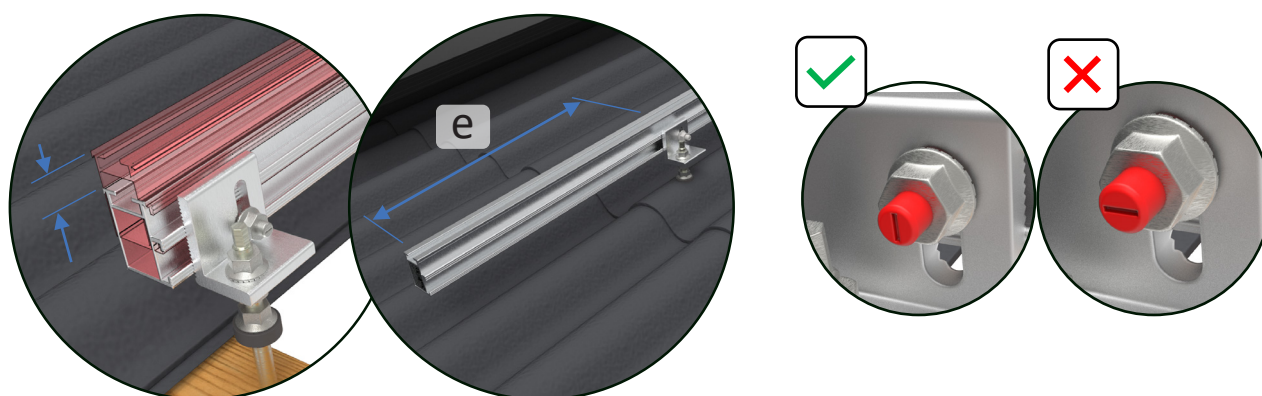

During the installation of the carriage profiles, as in the case of the ridge parallel carriage profiles, care shall be taken that the maximum end overhang does not exceed 400 mm (e). In relation to the roof perpendicular adjustment of the carriage profiles to the intended mounting plane, this is done in the same way via the extruded grooves in both the carriage profile and in the mounting bracket.

When the desired height is reached, tighten the nut on the hanger bolt so that the hammerhead bolt is rotated 90° at the same time as the nut is tightened (15 Nm). Once the tightening has been carried out, it is checked that the hammerhead bolt is engaged with the profile and oriented correctly.



4. Assembly of carriage profiles

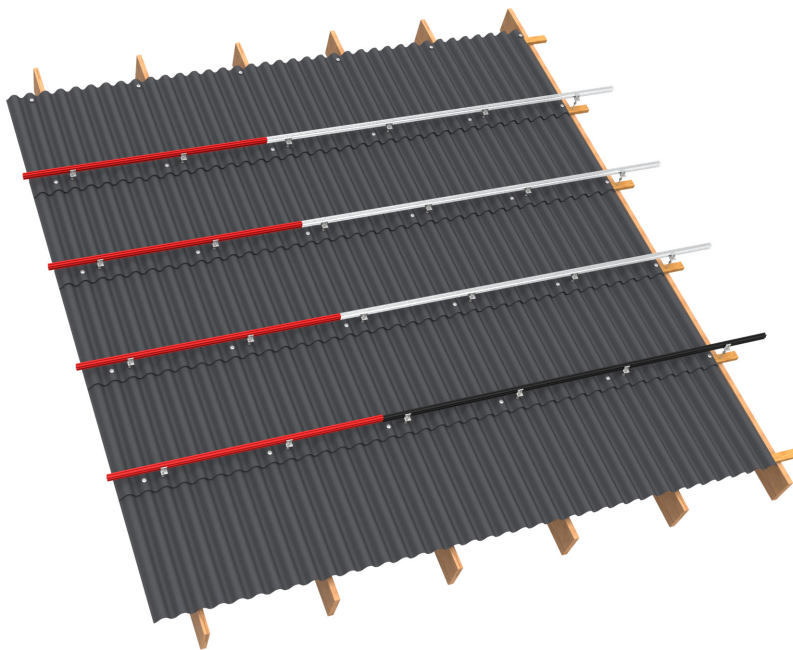

When carriage profiles are to be extended, it is a simple process where one profile connector is used for each carriage profile.

!! If long panel rows larger than 12 panels are installed, i.e. longer than 12–13 m, a thermal expansion must be made using the same profile connector (see further description below).

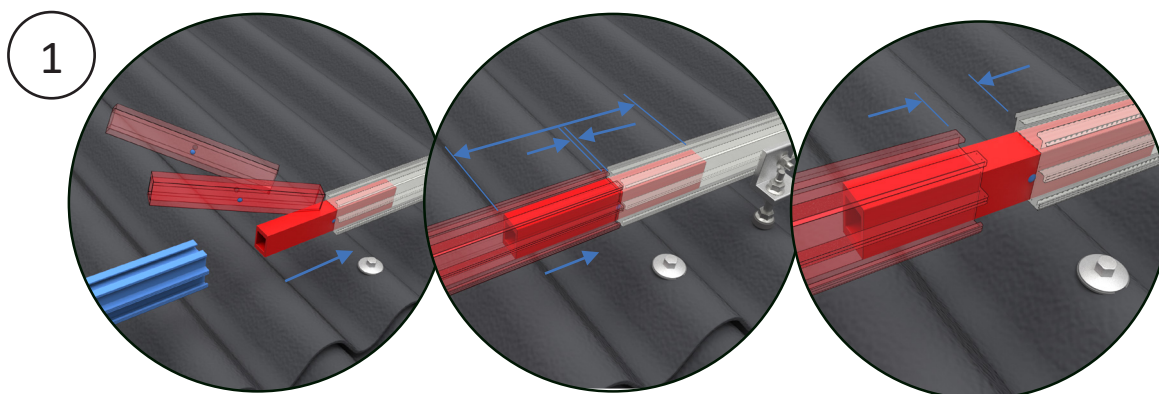

The profile connector is inserted into one profile by hand or with light blows from a soft hammer. In the middle of the profile connector there is a deformation mark which forms a stop, so that the profile connector ends up being located in the middle between the two assembled profiles. The profiles are pressed together around the profile connector until there is a remaining gap of up to 3 mm. For joints with thermal expansion, the gap should be 20–25 mm (for further information contact FIXNORDIC).



5. Installation of solar panels

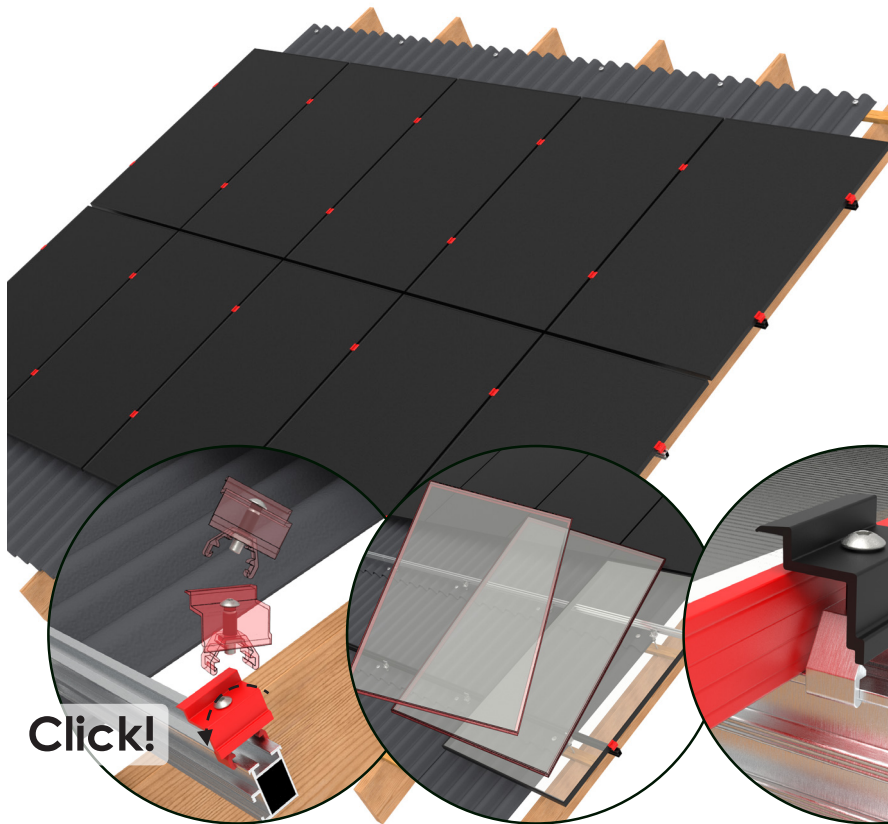

The illustration shows that end clamps must be mounted at the end of the panel rows as well as middle clamps between the panels.

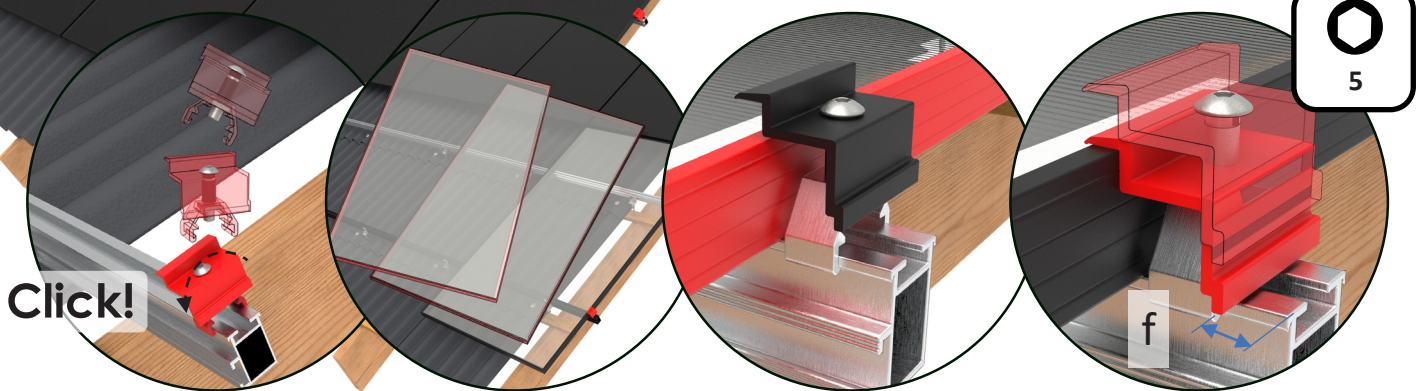

With the panel fixed on one side with the tightened end clamps, the middle clamps must be put in place. This is done in the same way as with the end clamp by clicking it into engagement with a rotating motion towards the top of the carriage profile. The middle clamp is held open like the end clamp by a rubber spring, and with the two pre-mounted middle clamps, the next panel can now be put in place. The middle clamp is tightened (12 Nm) and the mounting of the next panel can take place.

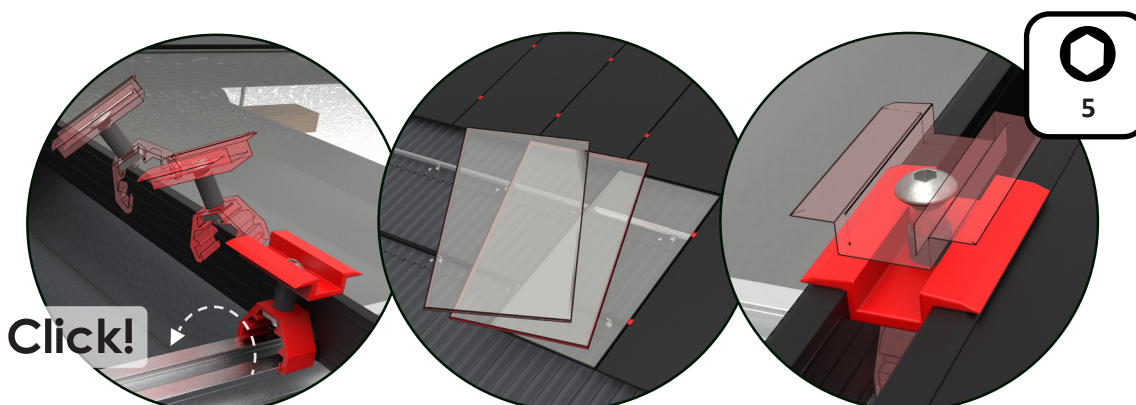

With the panel fixed on one side with the tightened end clamps, the middle clamps must be put in place. This is done in the same way as with the end clamp by clicking it into engagement with a rotating motion towards the top of the carriage profile. The middle clamp is held open like the end clamp by a rubber spring, and with the two pre-mounted middle clamps, the next panel can now be put in place. The middle clamp is tightened (12 Nm) and the mounting of the next panel can take place.



6. Installation of end covers

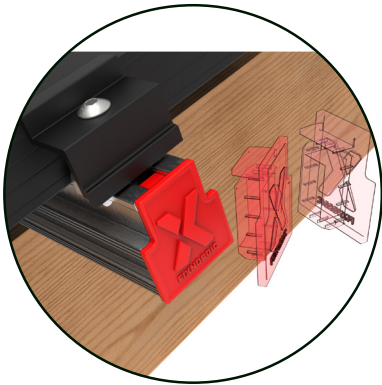

At the end of a panel row, the end cover is mounted into the profile end to keep these closed and so that there is a visually nice completion of the installation.

